

4x50

User's guide

Modbus TCP

4x50 Ethernet Module

Status and weight transfer using Modbus TCP



Software: MbConc4.160906.1v2
Doc. no.: MbConc4-160906-1v2a-eng
Date: 2023-02-06
Rev.: 1v2a

Contact:
Eilersen Electric A/S
Kokkedal Industripark 4
DK-2980 Kokkedal
Denmark
www.eilersen.com
info@eilersen.com
Tel: +45 49 180 100
Fax: +45 49 180 200

Contents

Contents.....	2
Introduction	4
Installation	4
How to	5
– Connect power supply.....	5
– Use the equipment in an ATEX (Ex) environment.....	5
– Connect the loadcells	5
– Set the sample time, scaling and filtering	5
- Connect 24VDC	6
– Set the IP Address, Subnet etc.	7
-Setup the Modbus TCP Master	8
Data processing	9
– Zeroing, calibration and weight calculation	9
– Zeroing of weighing system.....	9
– Corner calibration of weighing system	9
– Calculation of uncalibrated system weight.....	10
– System calibration of weighing system	10
Installation of System	11
- Checklist	11
Trouble shooting.....	11
Appendices	13
Appendix A – Filter specification.....	13
Appendix B – Loadcell error codes.....	14
Appendix C – Default Ethernet settings	14
Appendix D – Communication	15
Appendix E – Loadcell value scaling	16
Appendix F – Data formats.....	17
Appendix G – LED/Lamps	18
Appendix H – SW1 settings	18

Appendix I – Software download	18
Appendix J – Internal features	19
SW2 settings.....	19
LEDs/Lamps.....	19
4040 communication module.....	20
SW2 settings.....	20
Jumper settings.....	20
LEDs/Lamps.....	21
Revision History	22
Contact.....	22

Introduction

This document describes the use of a 4x50 Ethernet module from Eilersen Electric for Modbus TCP communication, when the software version listed on the front page is installed.

With the program specified on the front page, the 4x50 Ethernet module can transmit weight and status for up to 4 loadcells in Modbus TCP format.



It is possible to connect the 4x50 Ethernet module to a Modbus TCP Master. The 4x50 Ethernet module will act as a slave. It will then be possible from the Modbus TCP Master to read status and weight for each of the connected loadcells individually. Functions like zeroing, calibration and calculation of system weight(s) must be implemented **outside** the 4x50 in the Modbus TCP Master.

Installation

The system consists of 1-4 loadcells connected directly to the 4x40. Here an example with 4 loadcells is illustrated:

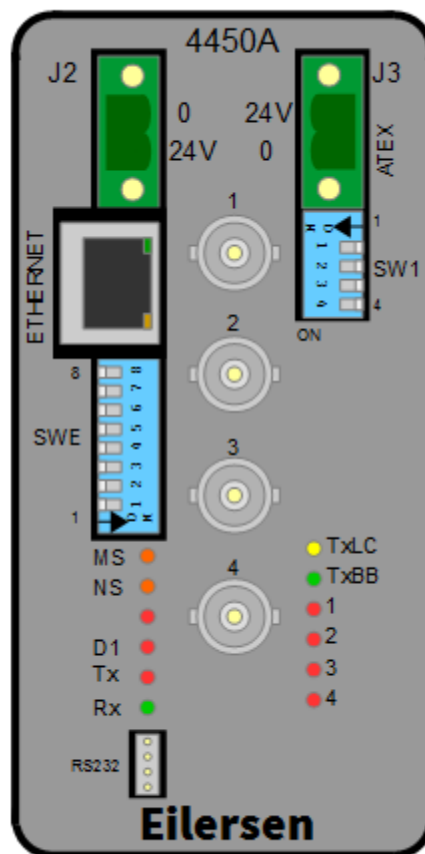

Before the 4x50 module is connected to the Modbus TCP Master the following steps must be performed:

- Install and connect the loadcells
- Select the desired sample time, scaling and filtering with the switches
- Connect 24VDC
- Set communication configuration (IP Address, Subnet mask etc.)

This can be done by the PC configuration software tool EEConnect – please refer to the separate user’s guide for EEConnect for further details

- Setup the Modbus TCP Master for communication with this module using the registers described below.

How to

– Connect power supply



IMPORTANT: Connection of power supply (24VDC) MUST be made to BOTH the green two pole power connectors (J2 and J3) as specified on the front panel of the 4x50 unit.

IMPORTANT: In regards to ATEX installations each of the green two pole power connectors (J2 and J3) MUST be connected to EACH of their own SEPARATE power supply as described later; see - *Connect 24VDC, page 6*.

– Use the equipment in an ATEX (Ex) environment



IMPORTANT: Instrumentation (the 4X50A) must be placed outside the hazardous zone if the load cells are used in hazardous ATEX (Ex) area. Furthermore, only ATEX certified load cells and instrumentation can be used in ATEX applications. Power supply MUST be done according to specification below in *section - Connect 24VDC, page 6*.

– Connect the loadcells

Connect the loadcells with BNC connector to BNC connectors marked 1-4. If not all connectors are use, the connections must be made from connector 1 and upwards.

– Set the sample time, scaling and filtering

The sample time, the weight signal scaling and the filtering can be selected on SWE:

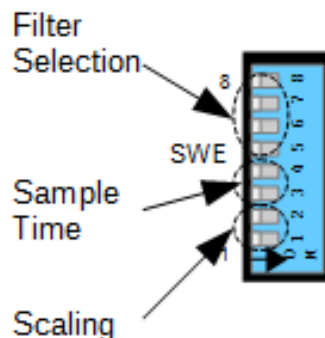

SWE.2	SWE.1	Weight result resolution
OFF	OFF	1 gram
OFF	ON	0.1 gram
ON	OFF	0.01 gram
ON	ON	10 gram

SWE.4	SWE.3	Sample time
OFF	OFF	20 ms
OFF	ON	100 ms
ON	OFF	200 ms
ON	ON	400 ms

SWE.5	SWE.6	SWE.7	SWE.8	Taps	Filter
OFF	OFF	OFF	OFF	-	No filter
ON	OFF	OFF	OFF	7	Fastest filter
OFF	ON	OFF	OFF	9	
ON	ON	OFF	OFF	9	
OFF	OFF	ON	OFF	12	
ON	OFF	ON	OFF	12	
OFF	ON	ON	OFF	15	
ON	ON	ON	OFF	17	
OFF	OFF	OFF	ON	21	Medium filter
ON	OFF	OFF	ON	25	
OFF	ON	OFF	ON	32	
ON	ON	OFF	ON	50	
OFF	OFF	ON	ON	64	
ON	OFF	ON	ON	67	
OFF	ON	ON	ON	85	
ON	ON	ON	ON	100	Strongest filter

Please see below in section *Appendix A – Filter specification, page 13*, for further details on filter specification

- Connect 24VDC

In a non-ATEX environment 24VDC are connected at **BOTH** J2 and J3.

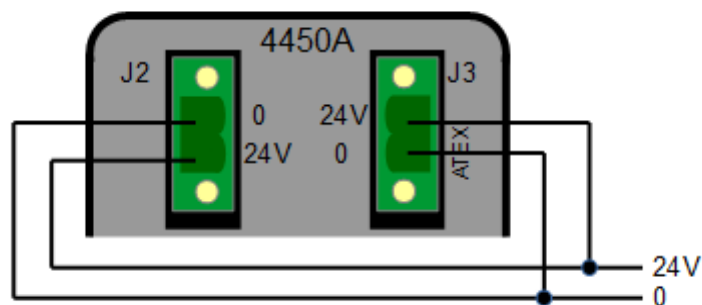

In an ATEX environment the 4x50 must be placed outside the hazardous zone and J3 must be supplied through the 4051A ATEX power supply:

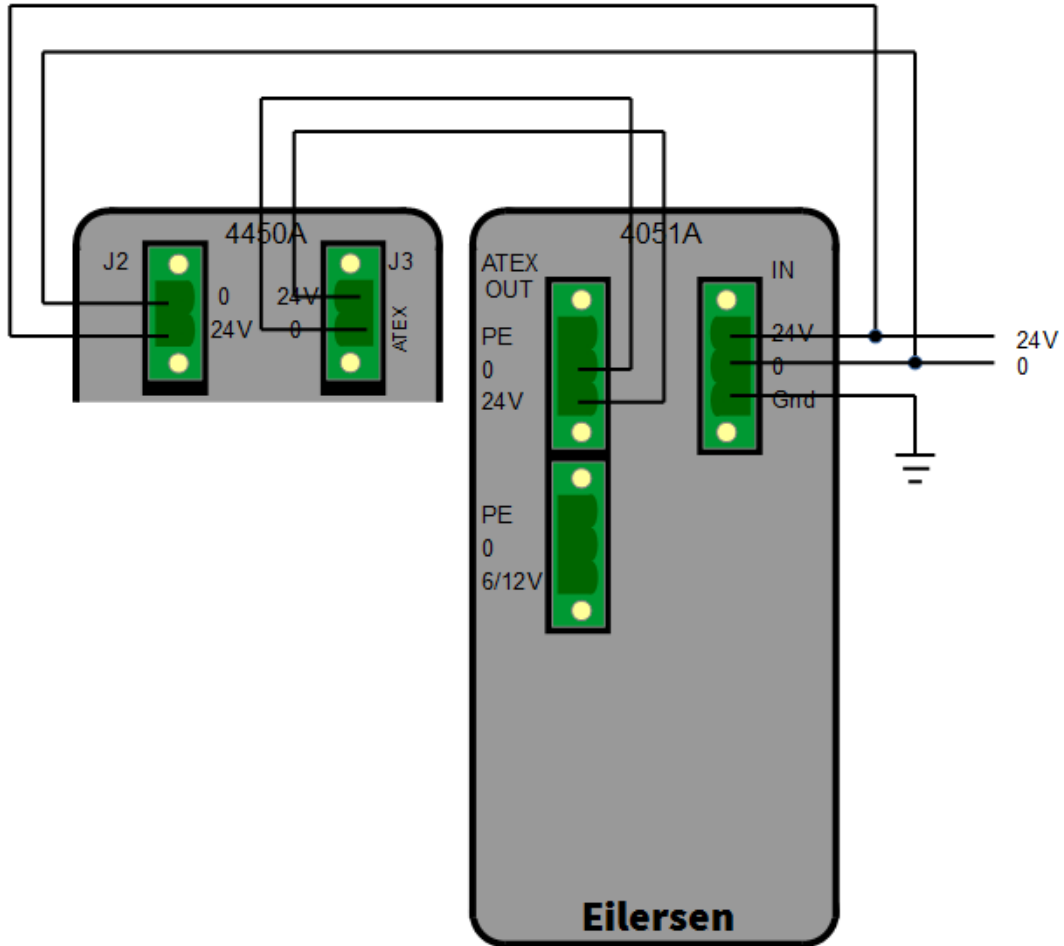

Safe Area



– Set the IP Address, Subnet etc.

All Ethernet parameters like IP address, Subnet mask etc. can be set by the EEConnect PC software tool. Please refer to the documentation for EEConnect for details.

-Setup the Modbus TCP Master

No registers can be written from the Modbus TCP. The following registers can be read:

- 40001 Word (2 byte register), 16 bit unsigned integer, used as bit register
LcRegister
Bits: 0-3: Expected loadcells
ON if the corresponding loadcell is expected to be connected
Bits: 14: Toggles ON and OFF with 1hz (=500ms ON, 500ms OFF)
Bit: 15: Always ON
- 40002 Word (2 byte register), 16 bit unsigned integer, used as bit register
LcStatus, loadcell 1
Bits ON to indicate error, value=0 means normal operation, no error present. Please see below *section Appendix B – Loadcell error codes, page 14* for details on error codes.
- 40003 Double Word (4 byte register), 32 bit signed integer
LcSignal, loadcell 1
Loadcell value as 32-bit signed integer according to selected scaling
- 40005 Word (2 byte register), 16 bit unsigned integer, used as bit register
LcStatus, loadcell 2
Bits ON to indicate error, value=0 means normal operation, no error present. Please see below *section Appendix B – Loadcell error codes, page 14* for details on error codes.
- 40006 Double Word (4 byte register), 32 bit signed integer
LcSignal, loadcell 2
Loadcell value as 32-bit signed integer according to selected scaling
- 40008 Word (2 byte register), 16 bit unsigned integer, used as bit register
LcStatus, loadcell 3
Bits ON to indicate error, value=0 means normal operation, no error present. Please see below *section Appendix B – Loadcell error codes, page 14* for details on error codes.
- 40009 Double Word (4 byte register), 32 bit signed integer
LcSignal, loadcell 3
Loadcell value as 32-bit signed integer according to selected scaling
- 40011 Word (2 byte register), 16 bit unsigned integer, used as bit register
LcStatus, loadcell 4
Bits ON to indicate error, value=0 means normal operation, no error present. Please see below *section Appendix B – Loadcell error codes, page 14* for details on error codes.
- 40012 Double Word (4 byte register), 32 bit signed integer
LcSignal, loadcell 4
Loadcell value as 32-bit signed integer according to selected scaling

Please notice that the value is only valid if the corresponding LcStatus register is 0 indicating no error present.

Please see further details on communication format, register allocation etc. below in *section Appendix D – Communication, page 15*.

Please see details on loadcell signal scaling below in *section Appendix E – Loadcell value scaling, page 16*.

Please notice that negative values are transmitted in 2-complement representation; please refer to *section Appendix F – Data formats, page 17* for further details.

Since only status and weight for the loadcells can be read, functions such as status handling, calculation of system weight(s), zeroing and calibration must be implemented in the Modbus TCP master. Please refer to the chapter *Data processing, page 9* for an explanation on how this typically can be done.

Data processing

– Zeroing, calibration and weight calculation

Calculation of system weight(s) is done by addition of the weight registers for the loadcells belonging to the system. This is explained below. Note that the result is only valid if all status registers for the loadcells in question indicate no errors. It should also be noted that it is up to the master to ensure the usage of consistent loadcell data when calculating the system weight; the used data should come from the same read of registers.

– Zeroing of weighing system

Zeroing of a weighing system (all loadcells in the specific system) should be performed as follows, taking into account that no loadcell errors may be present during the zeroing procedure:

1. The weighing arrangement should be empty and clean.
2. The Modbus TCP master verifies that no loadcell errors are present, after which it reads and stores the actual weight signals for the loadcells of the actual system in corresponding zeroing registers:

$$\text{LcZero}[X] = \text{LcSignal}[X]$$

3. After this the uncalibrated gross weight for loadcell X can be calculated as:

$$\text{LcGross}[X] = \text{LcSignal}[X] - \text{LcZero}[X]$$

– Corner calibration of weighing system

In systems where the load is not always placed symmetrically the same place (for example a platform weight where the load can be placed randomly on the platform when a weighing is to take place), a fine calibration of a systems corners can be made, so that the weight indicates the same independent of the position of the load. This is done as follows:

1. Check that the weighing arrangement is empty. Zero the weighing system.
2. Place a known load, $CalLoad$, directly above the loadcell that is to be corner calibrated.
3. Calculate the corner calibration factor that should be multiplied on the uncalibrated gross weight of the loadcell in order to achieve correct showing as:

$$CornerCalFactor[x] = (CalLoad) / (LcGross[x])$$

After this the determined corner calibration factor is used to calculate the calibrated gross weight of the loadcell as follows:

$$LcGrossCal[x] = CornerCalFactor[x] * LcGross[x]$$

– Calculation of uncalibrated system weight

Based on the loadcell gross values ($LcGross[x]$ or $LcGrossCal[x]$), whether they are corner calibrated or not, an uncalibrated system weight can be calculated as either:

$$Gross = LcGross[X1] + LcGross[X2] + \dots$$

or:

$$Gross = LcGrossCal[X1] + LcGrossCal[X2] + \dots$$

– System calibration of weighing system

Based on the uncalibrated system weight a system calibration can be made as follows:

1. Check that the weighing arrangement is empty. Zero the weighing system.
2. Place a known load, $CalLoad$, on the weighing arrangement.
3. Calculate the calibration factor that should be multiplied on the uncalibrated system weight in order to achieve correct showing as:

$$CalFactor = (CalLoad) / (Gross)$$

After this the determined calibration factor is used to calculate the calibrated system weight as follows:

$$GrossCal = CalFactor * Gross$$

If the determined calibration factor falls outside the interval 0.9 to 1.1 it is very likely that there is something wrong with the mechanical part of the system. This does not however apply to systems that do not have a loadcell under each supporting point. For example on a three legged tank with only one loadcell, you should get a calibration factor of approximately 3 because of the two “dummy” legs.

Installation of System

- Checklist

During installation of the system the following should be checked:

1. The loadcells are mounted mechanically and connected to BNC connectors in the front panel of the 4X50 unit
2. Set the scaling/resolution of the weight
3. Set the desired sampling time
4. Select the desired filter
5. The 4X50 Ethernet unit is connected to the Modbus TCP network using the RS45 Ethernet connector in the front panel
6. Configure the Modbus TCP master to communicate with the 4X50 Ethernet unit using parameter list
7. Connect the power
8. Setup IP Address etc. with EEConnect
9. Verify that the TxLC lamp (yellow) is lit (turns on after approx. 5 seconds)
10. Verify that the TxBB lamp (green) are lit (after 10 seconds)
11. Verify that NONE of the 1, 2, 3 or 4 lamps (red) are lit
12. Verify that the 4X50 Ethernet system unit has found the correct loadcells (LcRegister), and that no loadcell errors are indicated (LcStatus(x))
13. Verify that every loadcell gives a signal (LcSignal(x)) by placing a load directly above each loadcell one after the other (possibly with a known load)

The system is now installed and a zero and fine calibration is made as described above in *chapter Data processing, page 9*. Finally verify that the weighing system(s) returns a value corresponding to a known actual load.

Please note that in the above checklist no consideration has been made on which functions are implemented on the Modbus TCP master.

Trouble shooting

<i>Problem</i>	<i>Solution</i>
<i>No connection to device</i>	Link <i>Is the link LED lit on the device?</i> Yes : No link problem. No: Check the cabling; Check the power to the device and all switches between the PC and the device. If the PC is connected directly to the device check whether a crossed cable is needed. Check that the PC/switch connected directly to the device is capable of running at the device's Ethernet speed (10/100 MB/s) and duplex (half/full). Refer to the device's user's guide or reference manual for details on the device's speed and duplex. Firewall Connect the device directly to the PC, disable the firewall and retry the operation. REMEMBER to enable the firewall before anything but the Eilersen Electric device is connected to the PC. DO NOT run the PC with the firewall disabled while it is connected to switches, routers etc.

	<p>Software version in device</p> <p>Please notice that not all software version in the devices support setting of configuration on an Ethernet connection. Please refer to the device's user's guide or reference manual for details on how to set the configuration on the device.</p> <p>Different segments</p> <p>If the PC and device have IP addresses in different segments (taking into account the subnet mask on the PC and/or on the device) an advanced switch or a router may block the transmissions. If so connect the device directly to the PC and retry the operation.</p>

Appendices

Appendix A – Filter specification

SWE.5	SWE.6	SWE.7	SWE.8	Taps	Sample time				Damping
					20 ms	100 ms	200 ms	400 ms	
					Frequency				
Total pass time									
OFF	OFF	OFF	OFF	No filter					
ON	OFF	OFF	OFF	7	12.0 Hz 140 ms	2.4 Hz 0.7 s	1.2 Hz 1.4 s	0.6 Hz 2.8 s	-60dB
OFF	ON	OFF	OFF	9	10.0 Hz 180 ms	2.0 Hz 0.9 s	1.0 Hz 1.8 s	0.5 Hz 3.6 s	-60dB
ON	ON	OFF	OFF	9	12.0 Hz 180 ms	2.4 Hz 0.9 s	1.2 Hz 1.8 s	0.6 Hz 3.6 s	-80dB
OFF	OFF	ON	OFF	12	8.0 Hz 240 ms	1.6 Hz 1.2 s	0.8 Hz 2.4 s	0.4 Hz 4.8 s	-60dB
ON	OFF	ON	OFF	12	10.0 Hz 240 ms	2.0 Hz 1.2 s	1.0 Hz 2.4 s	0.50Hz 4.8 s	-80dB
OFF	ON	ON	OFF	15	8.0 Hz 300 ms	1.6 Hz 1.5 s	0.8 Hz 3.0 s	0.4 Hz 6.0 s	-80dB
ON	ON	ON	OFF	17	6.0 Hz 340 ms	1.2 Hz 1.7 s	0.6 Hz 3.4 s	0.3 Hz 6.8 s	-60dB
OFF	OFF	OFF	ON	21	6.0 Hz 420 ms	1.2 Hz 2.1 s	0.6 Hz 4.2 s	0.3 Hz 8.4 s	-80dB
ON	OFF	OFF	ON	25	4.0 Hz 500 ms	0.8 Hz 2.5 s	0.4 Hz 5.0 s	0.2 Hz 10.0 s	-60dB
OFF	ON	OFF	ON	32	4.0 Hz 640 ms	0.8 Hz 3.2 s	0.4 Hz 6.4 s	0.2 Hz 12.8 s	-80dB
ON	ON	OFF	ON	50	2.0 Hz 1000 ms	0.4 Hz 5.0 s	0.2 Hz 10.0 s	0.1 Hz 20.0 s	-60dB
OFF	OFF	ON	ON	64	2.0 Hz 1280 ms	0.4 Hz 6.4 s	0.2 Hz 12.8 s	0.1 Hz 25.6 s	-80dB
ON	OFF	ON	ON	67	1.5 Hz 1340 ms	0.3 Hz 6.7 s	0.15 Hz 13.4 s	0.075 Hz 26.8 s	-60dB
OFF	ON	ON	ON	85	1.5 Hz 1700 ms	0.3 Hz 8.5 s	0.15 Hz 17.0 s	0.075 Hz 34.0 s	-80dB
ON	ON	ON	ON	100	1.0 Hz 2000 ms	0.20 Hz 10.0s	0.10 Hz 20.0s	0.05 Hz 30.0s	-60dB

Appendix B – Loadcell error codes

Status codes for the connected loadcells are shown as a 4 digit hex number. If more than one error condition is present the error codes are OR'ed together.

Code Hex	Cause
0001	Reserved for future use
0002	Reserved for future use
0004	Reserved for future use
0008	Reserved for future use
0010	Power failure Supply voltage to loadcells is too low.
0020	New loadcell detected or loadcells swapped Power the system off and back on. Then verify that all parameters are acceptable.
0040	No answer from loadcell Bad connection between loadcell and loadcell module? Bad connection between loadcell module and communication module?
0080	No answer from loadcell Bad connection between load cell and 4015 load cell module? Bad connection between 4015 load cell module and 4040 communication module? Bad connection between 4040 communication module and 4050 module? Bad setting of DIP switches on 4040 communication module?
0100	Reserved for future use
0200	Reserved for future use
0400	Reserved for future use
0800	No loadcell answer Bad connection between 4040 communication module and 4050 module?
1000	Reserved for future use
2000	Reserved for future use
4000	Reserved for future use
8000	Reserved for future use

Please note that the above listed status codes are valid when the 4040 communication module is equipped with standard program.

Appendix C – Default Ethernet settings

The MAC address of the 4x50 unit is preset to a unique value within the Eilersen Electric A/S range. The default settings for IP address, Subnet mask etc. are:

IP address: 192.168.1.199
Subnet mask: 255.255.255.0
Port number: 502 (ModbusTCP default)

Appendix D – Communication

No registers can be written from the Modbus TCP. Registers can be read with Modbus TCP command: Read Holding Registers, function code 03.

IMPORTANT NOTICE: Registers that needs to be synchronized, e.g. both parts of a double word, or Loadcell signals for different loadcells on the same system MUST be read with ONE Read Holding Registers command

Data order: Standard Modbus, Big Endian, MSB first, also sometimes known as Motorola Format. Double words: LSW first.

Addressing: Standard Modbus Holding registers 40001 and upward, internal offset 0. Please see table below.

Length: Total length of data area is 26 bytes.

Modbus Address	Internal Read-Holding-Registers address	Size	Data value
40001	0 0x00	Word 16- bit	LcRegister Bit register
40002	1 0x01	Word 16- bit	LcStatus, loadcell 1 Bit register
40003	2 0x02	Double word 32 bit	LcSignal, loadcell 1 Signed integer
40005	4 0x04	Word 16- bit	LcStatus, loadcell 2 Bit register
40006	5 0x05	Double word 32 bit	LcSignal, loadcell 2 Signed integer
40008	7 0x07	Word 16- bit	LcStatus, loadcell 3 Bit register
40009	8 0x08	Double word 32 bit	LcSignal, loadcell 3 Signed integer
40011	10 0x0a	Word 16- bit	LcStatus, loadcell 4 Bit register
40012	11 0x0b	Double word 32 bit	LcSignal, loadcell 4 Signed integer

LcRegister

Bits: 0-3: Expected loadcells
ON if the corresponding loadcell is expected to be connected

Bits: 14: Toggles ON and OFF with 1hz (=500ms ON, 500ms OFF)

Bit: 15: Always ON

Word (2 byte register), 16 bit unsigned integer, used as bit register:

40001/ 0/0x00: Common LcRegister

LcStatus

Bits ON to indicate error, value=0 means normal operation, no error present. Please see *section Appendix B – Loadcell error codes, page 14* for details on error codes.

Word (2 byte register), 16 bit unsigned integer, used as bit register

40002/ 1/0x01: Loadcell 1

40005/ 4/0x04: Loadcell 2

40008/ 7/0x07: Loadcell 3

40011/10/0x0a: Loadcell 4

LcSignal

Loadcell value as 32-bit signed integer according to selected scaling

Double Word (4 byte register), 32 bit signed integer

40003/ 2/0x02: Loadcell 1

40006/ 5/0x05: Loadcell 2

40009/ 8/0x08: Loadcell 3

40012/11/0x0b: Loadcell 4

Appendix E – Loadcell value scaling

Below are some examples of how different loads are transferred in the LcSignal register, with different scaling selected

Weight In gram	SWE.2 = OFF SWE.1 = OFF 1 gram	SWE.2 = OFF SWE.1 = ON 0.1 gram	SWE.2 = ON SWE.1 = OFF 0.01 gram	SWE.2 = ON SWE.1 = ON 10 gram
1.0	1	10	100	0
123.4	123	1234	123400	12
12341	12341	123410	1234100	1234

Please notice that negative values are transmitted in 2-complement representation. ; please refer to *section Appendix F – Data formats, page 17* for further details.

Appendix F – Data formats

The Modbus TCP communication can transfer data in the following data formats. Please refer to other literature for further information on these formats as it is outside the scope of this document.

Unsigned integer format (16 bit): The following are examples of decimal numbers represented on 16 bit unsigned integer format:

<u>Decimal</u>	<u>Hexadecimal</u>	<u>Binary (MSB first)</u>
0	0x0000	00000000 00000000
1	0x0001	00000000 00000001
2	0x0002	00000000 00000010
200	0x00C8	00000000 11001000
2000	0x07D0	00000111 11010000
20000	0x4E20	01001110 00100000

Signed integer format (32 bit): The following are examples of decimal numbers represented in 32 bit signed (2-complement) integer format:

<u>Decimal</u>	<u>Hexadecimal</u>	<u>Binary (MSB first)</u>
-20000000	0xFECED300	11111110 11001110 11010011 00000000
-2000000	0xFFE17B80	11111111 11100001 01111011 10000000
-200000	0xFFFCF2C0	11111111 11111100 11110010 11000000
-20000	0xFFFFB1E0	11111111 11111111 10110001 11100000
-2000	0xFFFFF830	11111111 11111111 11111000 00110000
-200	0xFFFFF38	11111111 11111111 11111111 00111000
-2	0xFFFFF8	11111111 11111111 11111111 11111110
-1	0xFFFFF	11111111 11111111 11111111 11111111
0	0x00000000	00000000 00000000 00000000 00000000
1	0x00000001	00000000 00000000 00000000 00000001
2	0x00000002	00000000 00000000 00000000 00000010
200	0x000000C8	00000000 00000000 00000000 11001000
2000	0x000007D0	00000000 00000000 00000111 11010000
20000	0x00004E20	00000000 00000000 01001110 00100000
200000	0x00030D40	00000000 00000011 00001101 01000000
2000000	0x001E8480	00000000 00011110 10000100 10000000
20000000	0x01312D00	00000001 00110001 00101101 00000000

Appendix G – LED/Lamps

The front panel of the 4X50 system unit is equipped with a number of status lamps (light emitting diodes). These have the following functionality:

LED	FUNCTION
Ethernet connector (RJ45) Yellow	Link Ethernet is connected.
Ethernet connector (RJ45) Green	Activity Ethernet data is received or transmitted.
MS (Green/Red)	Module Status LED <i>Reserved for future use</i>
NS (Green/Red)	Network Status LED <i>Reserved for future use</i>
D1 (Red)	<i>Reserved for future use</i>
TX	RS232 TX RS232 data is transmitted
RX	RS232 RX RS232 data is received
TxLC (Yellow)	4040 communication with loadcells 4040 communication module is communicating with loadcells.
TxBB (Right) (Green)	4040 communication with 4050 Ethernet module (internal) 4040 communication module is transmitting to 4050 Ethernet module.
1 (Red)	Status for loadcell 1 Bad connection, loadcell not ready or other error detected.
2 (Red)	Status for loadcell 2 Bad connection, loadcell not ready or other error detected.
3 (Red)	Status for loadcell 3 Bad connection, loadcell not ready or other error detected.
4 (Red)	Status for loadcell 4 Bad connection, loadcell not ready or other error detected.

During power-on the 4X50 ethernet system unit will perform a hardware selftest. The test will cause the light emitting diodes D1, MS and NS to flash shortly one at a time.

Appendix H – SW1 settings

The front panel of the 4X50 system unit is equipped with a 4 pole DIP switch block named SW1. These switches are mounted on the 4040 communication module, and they are ONLY read during power-on.

SWITCH	FUNCTION
Sw1.1-Sw1.4	<i>Reserved for future use</i>

Appendix I – Software download

New software can be downloaded by the EEConnect PC software tool. Please refer to the documentation for EEConnect for details

Appendix J – Internal features

This appendix describes possible connections, DIP-switch settings and jumper settings that are available internally on the 4050 Ethernet module. These will normally be set from Eilersen Electric and should only be changed in special situations.

SW2 settings

The 4050 Ethernet module is internally equipped with a 8 pole DIP switch block named SW2. This DIP switch block has the following function:

SWITCH	FUNCTION
Sw2.1-Sw2.8	<i>Reserved for future use</i>

LEDs/Lamps

The 4050 Ethernet module is internally equipped with 4 LEDs. These LEDs have the following functionality:

LED	FUNCTION
D4 (Yellow)	RS485 RX Data is received from 4040.
D8 (Red)	RS485 Enable Transmission to the 4040 is enabled.
D9 (Green)	RS485 TX Data is transmitted to the 4040.
D10 (Red)	Power 3.3 VDC internal power supply is on.

4040 communication module

For information on jumper settings, DIP-switch settings, LED status lamps etc. on the 4040 communication module that is not covered in the above, please refer to the separate documentation that describes the 4040 communication module and its specific software.

SW2 settings

The 4040 communication module is internally equipped with a 8 pole DIP switch block named SW2. Please note that these switches are **ONLY** read during power-on. This DIP switch block has the following function when the 4040 communication module is equipped with standard program:

Sw2.1	Sw2.2	Sw2.3	Number of loadcells
OFF	OFF	OFF	1
ON	OFF	OFF	1
OFF	ON	OFF	2
ON	ON	OFF	3
OFF	OFF	ON	4
ON	OFF	ON	5
OFF	ON	ON	6
ON	ON	ON	6

SWITCH	FUNCTION
Sw2.4-Sw2.8	<i>Reserved for future use</i>

Jumper settings

The 4040 communication module is internally equipped with 4 jumpers named P2, P3, P4 and P5. In this system these jumpers must be set as follows:

JUMPER	POSITION
P2	OFF (Loadcell connected to 4040 NOT accessible using SEL1)
P3	OFF (Loadcell connected to 4040 NOT accessible using SEL6)
P4	OFF (Loadcell connected to 4040 NOT accessible using SEL1)
P5	OFF (Loadcell connected to 4040 NOT accessible using SEL6)

LEDs/Lamps

The 4040 communication module is internally equipped with a number of status lamps (light emitting diodes). The lamps have the following functionality when the 4040 communication module is equipped with standard program:

LED	FUNCTION
<i>D11</i> <i>(Red)</i>	<i>Reserved for future use</i>
<i>D12</i> <i>(Red)</i>	<i>Reserved for future use</i>
<i>D13</i> <i>(Red)</i>	<i>Reserved for future use</i>
<i>D14</i> <i>(Red)</i>	<i>Reserved for future use</i>

Revision History

Date	Author	Rev.	Update
2016-09-12	joke	1v0	<i>Initial document created.</i>
2018-10-31	jk	1v0a	<i>Modbus register numbers and internal addresses corrected</i>
2019-09-10	HJA	1v1	<i>Updated references to software ID.</i>
2020-09-11	HJA	1v1a	<i>Added that both power connectors must be connected to 24VDC.</i>
2022-03-23	HJA	1v2	<i>Changed description for loadcell error codes (0080 and 0800).</i>
2023-02-06	HJA	1v2a	<i>Corrected error in Modbus register (40010 -> 40011) . Added appendix for default Ethernet settings.</i>

Contact

With further questions or improvement suggestions please contact us:

Eilersen

The Weighing Experts

Eilersen Electric A/S
Kokkedal Industripark 4
DK-2980 Kokkedal
Denmark
www.eilersen.com
info@eilersen.com
Tel: +45 49 180 100
Fax: +45 49 180 200