

5024G

Options Guide

External Module

5024G LCD weighing terminal

External module option: MCE9637, MCE2035, 2050 or 2070



Software: StdLim.140630.6v8x
Doc. no.: StdLim-140630-6v8-OG-ExtModule-eng
Date: 2025-02-26
Rev.: 6v8

Contact:
Eilersen Electric A/S
Kokkedal Industripark 4
DK-2980 Kokkedal
Denmark
www.eilersen.com
info@eilersen.com
Tel: +45 49 180 100
Fax: +45 49 180 200

Contents

Contents	2
Introduction	5
Installation of external module	5
How to	5
– Enable and configure external module on 5024G.....	5
Enable or change Device Type.....	6
Set/Read Device Address	6
Set/Read Endian	6
Read Status	6
Read Error Counter	6
Set/Read Bytes Out.....	7
Set/Read Bytes In.....	7
– Monitor external module data on 5024G	7
Protocol description.....	8
– External communication using PPO.....	8
– MOD	8
MDS.....	9
– PCV Description.....	9
PCA.....	9
PNU.....	10
PVA.....	10
– PCD Description	10
CTW/STW.....	10
MRV/MAV.....	11
– Communication overview	11
– RS – Reference Value Selector, MRV – Main Reference Value.....	11
– AS – Actual Value Selector, MAV – Main Actual Value.....	11
– CTW – Control Word	12
– STW – Status Word	12
– Parameters.....	13

Trouble shooting.....	15
Appendices	16
Appendix A – Screens overview	16
Appendix B – Electrical connection of 5024G to external module	17
Rear view	17
RS485 communication connector on 5024G	17
Appendix C – MCE2035 Profibus-DP module	18
MCE2035 Profibus-DP specification	18
MCE2035 Checklist during installation	18
MCE2035 Connection.....	18
MCE2035 DIP-switch settings.....	19
MCE2035 Jumper settings.....	19
MCE2035 Light Emitting Diodes	20
MCE2035 Profibus-DP connector	20
Appendix D – 2070 PROFINET module	21
2070 Checklist during installation	21
2070 Connection without MCE9601.....	21
2070 Connection with MCE9601.....	22
2070 DIP-switch settings	22
2070 Jumper settings	22
2070 Light Emitting Diodes	23
2070 PROFINET connector	24
Appendix E – MCE9637 DeviceNet module	25
MCE9637 DeviceNet specification.....	25
MCE9637 Checklist during installation	25
MCE9637 Connection.....	25
MCE9637 DIP-switch settings.....	26
MCE9637 Jumper settings.....	27
MCE9637 Light Emitting Diodes	27
MCE9637 DeviceNet connector	28
Appendix F – 2050 Ethernet-IP module.....	29
2050 Ethernet-IP specification	29
2050 Checklist during installation	29

2050 Connection without MCE9601.....	29
2050 Connection with MCE9601.....	30
2050 DIP-switch settings	30
2050 Light Emitting Diodes	31
2050 RS232 connector (J4).....	33
2050 Ethernet connector (J8).....	33
Appendix G – 2050 Setup and Terminal Interface	33
2050 IP address setting	34
Appendix H – 2050 Ethernet-IP connection to Allen Bradley.....	35
Ethernet-IP communication – Master input.....	35
Ethernet-IP communication – Master output.....	36
Appendix I – 2070 Tips for PROFINET configuration	36
MAC addresses	36
GSDML file	36
Factory settings.....	36
Setting DeviceName, IP Address etc.....	37
Data sizes	37
Revision History	38
Contact	39

Introduction

This document describes the use of the External Module option on the 5024G Weighing Terminal from Eilersen Electric. With the software version stated on the front page and with the External Module option enabled as well as a on RS485 externally connected communications module (MCE2035, 2070, MCE9637 or 2050) from Eilersen Electric the system can communicate with an external controller/PLC using Profibus-DP, PROFINET, DeviceNet or Ethernet-IP.

With the later stated software versions installed in the external module the external communication module can transfer 14 input bytes from the 5024G terminal to the Profibus-DP / PROFINET / DeviceNet / Ethernet-IP master, and transfer 14 output bytes from Profibus-DP / PROFINET / DeviceNet / Ethernet-IP master to the 5024G terminal.

Exchange of data between 5024G terminal and the external controller/PLC is made according to the profile/protocol described later (see **Protocol description**).

This manual only describes the External Module option. For general information on the operation of the 5024G please see the 'Users guide'.

Installation of external module

The used external module (xxxx) must be connected to the 5024G weighing terminal and to the external controller/PLC according to the description in the appropriate appendix.

Please notice:



- no matter what module type, the module must be connected to the 5024G terminal using a RS485 connection.
- depending on module type, the module must be connected to the external controller/PLC using bus type as described in the appendix belonging to the module.
- depending on module type, the 5024G terminal must be configured to exactly the module used according to the guidelines below.

How to

– Enable and configure external module on 5024G

Below the **EXTERNAL MODULE** screen is shown when a MCE2035 (MCExx35) module has been enabled.

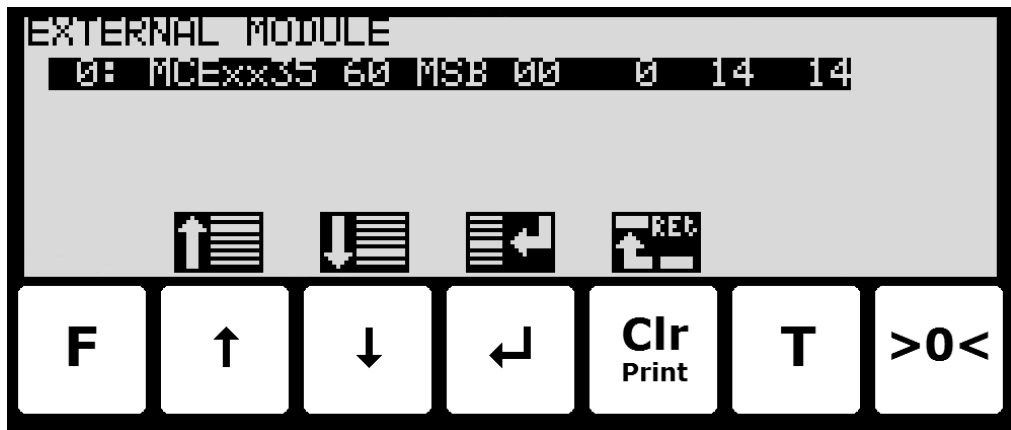

In this screen the external module is shown and can be changed. A cursor (inverted text) indicates the currently selected module. With this version of the software only one module can be installed.

The line with module data shows in forth running order after the Device Index (always 0 in this software version): Device Type, Device Address, Endian, Status, Error Counter, Bytes Out and Bytes In, which all are described in detail below.

Enable or change Device Type

To enable or select a new module type (Device Type) press  on the selected line, and from the **EXTERNAL MODULE** menu select the **DEVICE TYPE** menu item to get the selection list with possible module types. Possible module types are **MCExx35** Profibus-DP module, **MCE9637** DeviceNet module, **2050** Ethernet module and **2070** PROFINET module. If no external module is enabled the 5024G display will show "-----" / "None".

Once a module type is enabled/selected the other settings (see descriptions below) are set to default values, which should normally be used.

Set/Read Device Address

The address is the entered address plus the base address for the module type selected.

During change enter a number in the interval 0-15. With this software version where only one external module can be connected, 0 is the normally entered address value.

Set/Read Endian

Endian of the individual data values transferred: *MSB* most significant byte first: Big endian. *LSB* least significant byte first: Little endian. *MSB* is normally used with Profibus-DP and PROFINET while *LSB* is normally used with all other types of modules.

Read Status

00: Communication up and running.

40: Connection established earlier to the module has been lost.

80: No connection to the module has been established.

Read Error Counter

Current number off errors in communication.

Set/Read Bytes Out

Number of bytes to be sent from the 5024G to the external module and from there to the Profibus-DP/PROFINET/DeviceNet/Ethernet master. This is the number of input bytes in the Profibus-DP/PROFINET/DeviceNet/Ethernet master.

The value must be the same as the value in the external module. Normally this is 14.

Set/Read Bytes In

Number of bytes to be received in the 5024G from the external module and transmitted from the Profibus-DP/PROFINET/DeviceNet/Ethernet master. This is the number of output bytes in the Profibus-DP/PROFINET/DeviceNet/Ethernet master.

The value must be the same as the value in the external module. Normally this is 14.

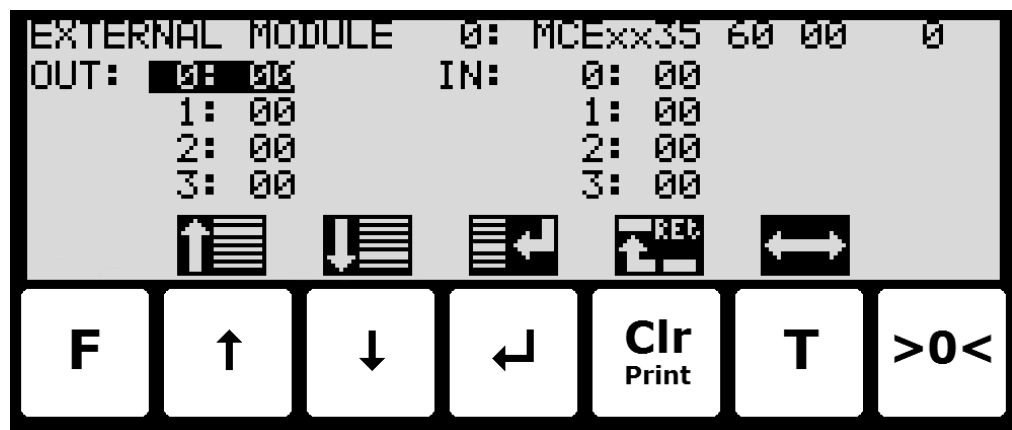

– Monitor external module data on 5024G

Below the **EXTERNAL MODULE DATA** screen is shown when a MCE2035 (MCExx35) module has been enabled.



This screen will show the data sent to the external module (*OUT*) and the data received from the external module (*IN*).

The following keys can be used for the described special functions:

-  Selects entry of the selected input data byte for test purposes. If an external module is communication the value will immediately be overwritten by the value received from the external module.
-  Toggles the cursor between the output and the input bytes.

Protocol description

– External communication using PPO

The communication with the external module is made using a '*parameter-process data object*' (PPO) consisting of 14 bytes data. This telegram (object) is used during both reception and transmission of data. The structure of this telegram is as follows:

MOD		PCV						PCD					
MDS	PCA	PNU		PVA				CTW		MRV			
								STW		MAV			
1	2	3	4	5	6	7	8	9	10	11	12	13	14

Byte 1

Byte 14

The telegram is made up of 3 blocks; a MOD part (1 byte), a PCV part (the next 7 bytes) and a PCD part (the last 6 bytes). The three blocks are as follows:

MOD (Mode)

MDS (Byte 1): Mode selector

PCV (Parameter-Characteristic-Value)

PCA (Byte 2): Parameter Characteristics

PNU (Bytes 3-4): Parameter number

PVA (Bytes 5-8): Parameter value

PCD (Process Data)

CTW (Bytes 9-10) (Master to Slave): Control Word

STW (Bytes 9-10) (Slave to Master): Status Word

MRV (Bytes 11-14) (Master to Slave): Main Reference Value

MAV (Bytes 11-14) (Slave to Master): Main Actual Value

In the following the meaning of the individual blocks of the telegram is explained further.



IMPORTANT: During transfer/reception of data (i.e. the MAV) it is up to the master (the PLC) to ensure consistent data, when a parameter consisting of several bytes is read/updated and when AS/MAV or RS/MRV is read/set.

– MOD

The MOD part of the telegram indicates which value is to be transferred as **Main Reference Value** (MRV) and as **Main Actual Value** (MAV). Please see below for further information.

MDS

MDS contains an RS part for selection of **Main Reference Value** (MRV) and an AS part for selection of **Main Actual Value** (MAV), as shown in the figure below.

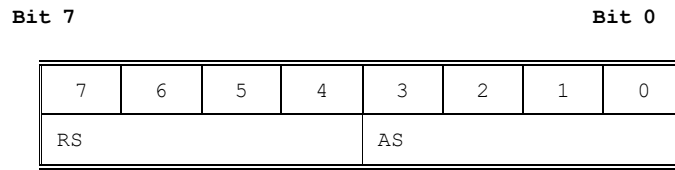

RS: Reference value selector (Values: 0..15)

AS: Actual value selector (Values: 0..15)

– PCV Description

The PCV part of the telegram is made up of a PCA part, a PNU part and a PVA part. The function of these different parts of the PCV part is described here.

PCA

The PCA part contains an RC part for 'request' and 'response' indication.

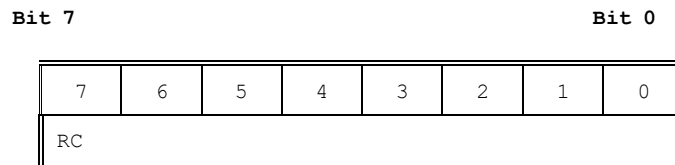

RC: Request/Response Characteristics (Values: 0..255)

RC is used by the master to tell the slave which 'request' is desired. Similarly the slave uses RC to inform the master the status of the received 'request' ('response'). The contents of RC has the following function during 'request':

REQUEST	FUNCTION
0	No request
1	Request parameter value
2	Change parameter value (2 bytes)
3	Change parameter value (4 bytes)
<i>Others</i>	<i>Reserved for future use</i>

The contents of RC has the following function during response:

RESPONSE	FUNCTION
0	No response
1	Transfer parameter value (2 bytes)
2	Transfer parameter value (4 bytes)
3	Request rejected (incl. Error#, see later)
4	Cannot be serviced by PCV interface
<i>Others</i>	<i>Reserved for future use</i>

PNU

The PNU part indicates the parameter number of the parameter to be read/changed. The parameters and their function is described below.

PVA

The PVA part contains 4 bytes for reception and transmission of parameter values. The PVA part transfers '2 byte' parameters in bytes 5 and 6, while '4 byte' parameters are transferred in bytes 5 and 8.

If the slave rejects a request from the master the RC part assumes the value 3 (see above) and the error number itself is transferred in the PVA part (bytes 5 and 6). The following error indications are possible:

ERROR #	CAUSE
0	Illegal command for this PNU or PNU not used.
1	<i>Reserved for future use</i>
2	Upper or lower limit exceeded

– PCD Description

The PCD part of the telegram is made up of a CTW/STW part and a MRV/MAV part. The function of these two parts of the PCD part is described here. Note that the PCD part (the last 6 bytes) always transfers these data disregarding the contents of the PCV part.

CTW/STW

During communication from the master to the slave, the first two bytes of the PCD part are used as a Control Word (CTW). Using the Control Word (CTW) it is possible to tell the slave how to react as different commands can be transferred to the slave.

During communication from the slave to the master, the first two bytes of the PCD part are used as a Status Word (STW). Using the Status Word (STW) it is possible for the master to gain information on the status of the slave.

MRV/MAV

During communication from the master to the slave the last four bytes of the PCD part are used as a **Main Reference Value** (MRV); a setpoint. Using the RS defines exactly which value is transferred as MRV.

During communication from the slave to the master the last four bytes of the PCD part are used as a **Main Actual Value** (MAV); the actual value. Using the AS defines exactly which value is transferred as MAV.

– Communication overview

Please note the following:

1. All weights are transferred as shown in the display without a decimal point (i.e. 300.0 kg is transferred as 3000 and 67.2 kg is transferred as 672).
2. All negative numbers are transferred as 2-complement numbers.
3. Actual unit and decimal point position can be read from the appropriate parameter.

– RS – Reference Value Selector, MRV – Main Reference Value

RS	MRV
Reference Value Selector	Main Reference Value
0	<i>Not used</i>
<i>Others</i>	<i>Not used</i>

– AS – Actual Value Selector, MAV – Main Actual Value

AS	MAV
Actual Value Selector	Main Actual Value
0	<i>Not used</i>
1	Actual gross weight
2	Actual net weight
<i>Others</i>	<i>Not used</i>

Actual gross weight is the actual gross weight on the 5024G terminal.

Actual net weight is the actual net weight on the 5024G terminal.

- CTW – Control Word

Bit	Function
0	Zero
1	Autotare (zero of net weight)
2	Start dosing
3	Stop dosing
4	Registration
<i>Others</i>	<i>Not used</i>

Zero must be activated if a zero of the gross weight is desired.

Autotare must be activated if a zero of the net weight is desired.

Start dosing must be activated if a start of dosing is desired.

Stop dosing must be activated if a dosing is to be stopped before the fine limit is reached. If the terminal is set to perform automatic registration on time this will take place afterwards.

Registration must be activated if a registration of the actual net weight is desired. Any dosing in progress will be aborted before registration.

- STW – Status Word

Bit	Function
0	Weight reading not possible
1	Zero OK
2	Zero not possible
3	Autotare OK
4	Autotare not possible
5	Start dosing OK
6	Start dosing not possible
7	Stop dosing OK
8	Stop dosing not possible
9	Registration OK
10	Registration not possible
11	Fine dosing
12	Coarse dosing
13	<i>Not used</i>
14	Registration ready
15	OK – always ON

Weight reading not possible is active when the 5024G terminal is unable to determine weight.

Zero OK is active when zero was possible.*)

Zero not possible is active when zero was NOT possible.*)

Autotare OK is active when autotare was possible.*)

Autotare not possible is active when autotare was NOT possible.*)

Start dosing OK is active when start of dosing was possible.*)

Start dosing not possible is active when start of dosing was NOT possible.*)

Stop dosing OK is active when stop of dosing was possible.*)

Stop dosing not possible is active when stop of dosing was NOT possible.*)

Registration OK is active when registration of net weight was possible.*)

Registration not possible is active when registration of net weight was NOT possible.*)

Fine dosing is active during dosing until the fine limit (pos. adjusted for afterflow) is reached.

Coarse dosing is active during dosing when the net weight is below the coarse limit.

Registration ready is active when a registration is ready. The bit is cleared when a new dosing is started.

OK – always ON is always activated. Can be used as a control of the communication.

Bits marked with *) are cleared again when the corresponding request bit is cleared.

– Parameters

NO	TYPE	PARAMETER
1	4, R	Actual gross weight
2	4, R	Actual net weight
3	4, RW	Fine limit
4	4, RW	Coarse limit
5	-	<i>Not used</i>
6	4, R	Last registered amount
7	4, R	Total dosed amount
8	4, R	Total number of weighings
10	2, R	Unit <i>0: kg</i> <i>1: lbs</i> <i>2: gram</i>
11	2, R	Decimal point position
20 - 35	2, R	Load cell-Status[x]
40 - 55	4, R	Load cell-Gross[x]
<i>Others</i>		<i>Not used</i>

Actual gross weight is the actual gross weight on the 5024G terminal.

Actual net weight is the actual net weight on the 5024G terminal.

Fine limit contains the fine limit used during dosing.

Coarse limit contains the coarse limit used during dosing.

Last registered amount contains the result (registration) of the last dosing.

Total dosed amount contains the total dosed amount.

Total number of weighings contains the total number of weighings.

Unit indicates the unit used in the display reading. It should be used to scale weight indications received/transmitted using the Profibus-DP/PROFINET/DeviceNet/Ethernet-IP communication.

Decimal point position indicates the number of digits after the decimal point in the display reading. It should be used to scale weight indications received/transmitted using the Profibus-DP/PROFINET/DeviceNet/Ethernet-IP communication.

Load cell-Status[x] contains the actual status for load cell x.

Load cell-Gross[x] contains the actual gross signal (not zeroed) on load cell x.

Trouble shooting

Problem	Explanation and possible solutions
<i>PLC unable to receive/transmit data from/to 5024G</i>	<p>Check connection between PLC and external module is ok (see below).</p> <p>Check connection between 5024G and external module is ok (see below).</p>
<i>No connection between PLC and external module</i>	<p>Check the field bus cabling between 5024G and PLC is made correctly.</p> <p>Check possible termination of field bus is made correctly.</p> <p>Check the external module is powered correctly.</p> <p>Check the PLC is configured correctly possibly using the supplied configuration file.</p> <p>If possible check the field bus communication address is set correctly using DIP switches or configuration tool.</p> <p>Check if status lamps on external module indicate connection to PLC is ok.</p>
<i>No connection between 5024G and external module</i>	<p>Check the RS485 connection between 5024G and external module is made correctly.</p> <p>Check the external module is powered correctly.</p> <p>Check the AUX (RS485) communication address is set correctly on the external module using its DIP switches.</p> <p>If possible check status lamps (typical TXBB and D1) on external module indicate communication with 5024G (typical they will toggle).</p> <p>Check parameters in EXTERNAL MODULE screen are configured correctly:</p> <ul style="list-style-type: none"> - Check "Device Type" parameter matches external module type. - Check "Address" parameter corresponds to DIP switch setting on external module. - Check "Bytes Out" parameter matches specification in configuration file; typical 14 for this application. - Check "Bytes In" parameter matches specification in configuration file; typical 14 for this application.
<i>Values change rapidly between random values</i>	Check " Endian " parameter selected in EXTERNAL MODULE screen corresponds to the used field bus and PLC type.
<i>Implemented protocol does not behave as expected</i>	Use the EXTERNAL MODULE DATA screen to debug 5024G received data from PLC (IN) results in expected transmit data to PLC (OUT).

Appendices

Appendix A – Screens overview

The system has the following screens, which are selected using the menu system. With the external module option enabled an **EXT. MODULE** screen and a **DATA** screen is added:

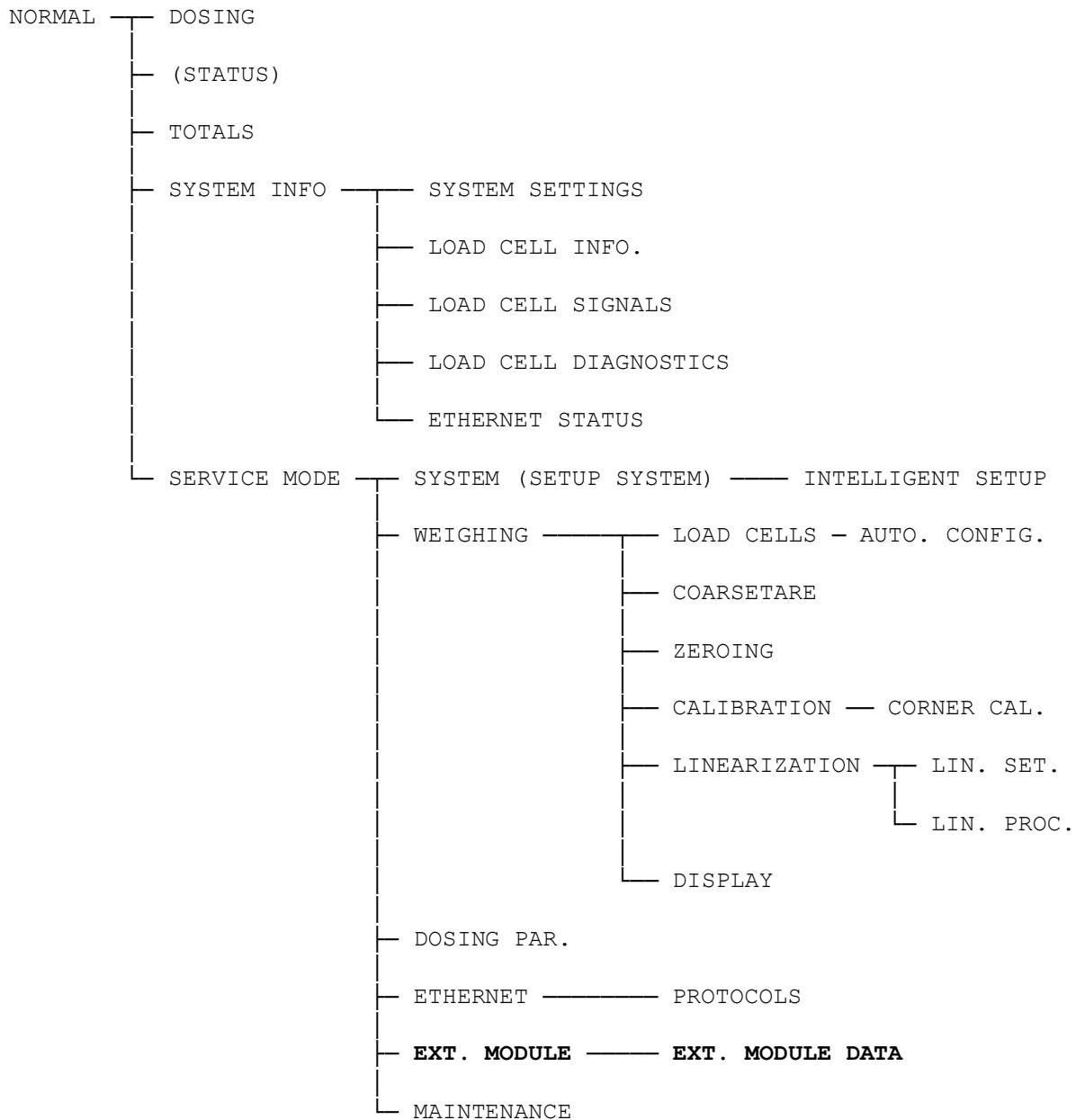

Appendix B – Electrical connection of 5024G to external module

The following describes the electrical connection of the 5024G terminal to a general external module using a RS485 connection.

Rear view

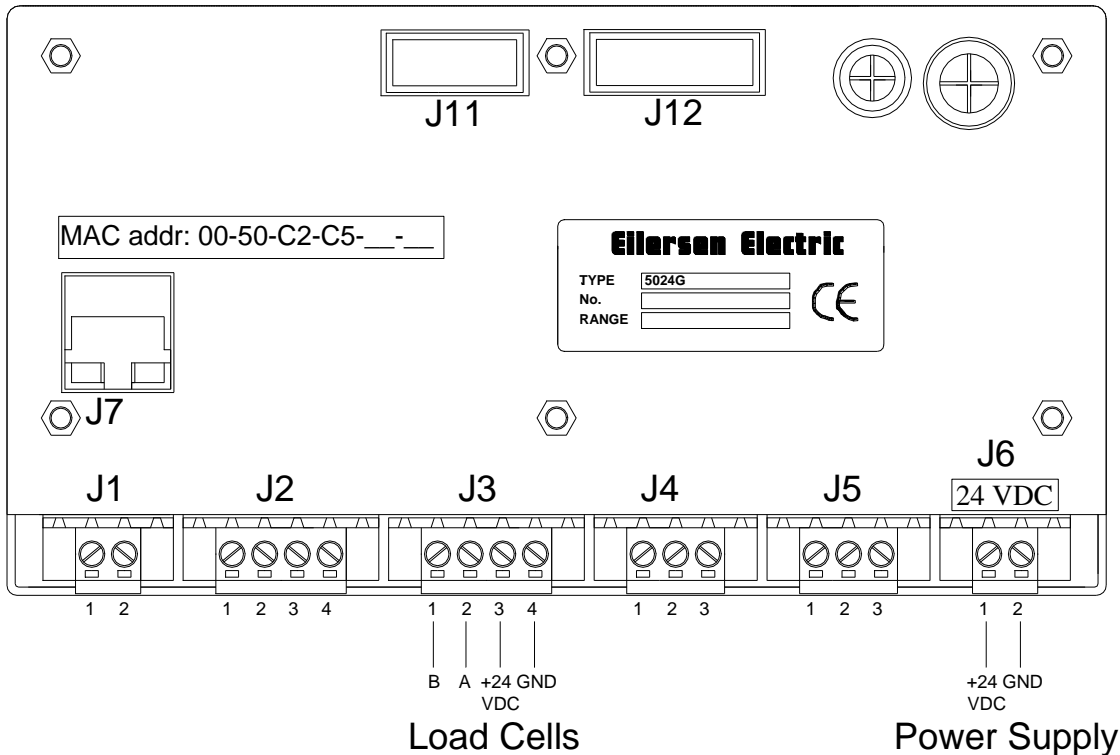

RS485 communication connector on 5024G

The 3 pin RS485 serial communication connector (J4) on the 5024G can be used for RS485 communication with external equipment. This connector has the following connections:

J4 pin	Function	Connection
1	RS485-B (negative line)	External module MCE9601: B or RS485-B on communication connector on the external module.
2	RS485-A (positive line)	External module MCE9601: A or RS485-A on communication connector on the external module.
3	RS485-GND	External module MCE9601: GND or RS485-GND on communication connector on the external module.

Please notice: A and B line definition may be switched on external equipment. Especially on Siemens equipment and a few other German manufacturers A and B lines definitions are different.

IMPORTANT: Remember to supply power to any external communication module used. This can be done by connecting +24V and GND (possibly taken from the J1 or J6 connector on the 5024G terminal) to the used MCE9601 connection module or directly to any power connector on the external module.



Appendix C – MCE2035 Profibus-DP module

If a 2035 Profibus-DP module is connected it must have the following software version:

MCE2035.AUXSLAVE.050909.0 (or newer)

It is possible to connect the 2035 communication module on a PROFIBUS-DP network, where it will act as a slave. It will then be possible from the PROFIBUS-DP master to transfer data to/from the 5024G terminal (RS485 master).

MCE2035 Profibus-DP specification

The 2035 communication module confirms to the following PROFIBUS-DP specifications:

Protocol:	Profibus-DP
Communications form:	RS485
Module type:	Slave
Baud rates [kbit/sec]:	9.6, 19.2, 93.75, 187.5, 500, 1500, 3000, 6000, 12000
Profibus-DP address:	0-127 (Sw2.2-Sw2.8)
Profibus-DP connection:	9-pin sub-D (female) connector

MCE2035 Checklist during installation

During installation of the system the following should be checked/performed:

- 1) The Profibus-DP master is configured to communicate with the Profibus-DP module (2035) using the supplied GSD file.
- 2) The Profibus-DP module (2035) is connected to the Profibus-DP network, and a possible termination at the Profibus-DP slave is made.
- 3) The Profibus-DP module (2035) address is set using Sw2.2- Sw2.8. Power is applied, and the Profibus-DP communication is started.
- 4) Check that yellow LEDs (DES and RTS) of the Profibus-DP module (2035) are lit/flashing, and that the green LED (D1) flashes. Check that the TXBB LED on the Profibus-DP module flashes and that the red LED (PBE) is not lit.

MCE2035 Connection

The 10-pole connector (J2) on the 2035 module is connected to the 10-pole connector on the MCE9601 connection module using the supplied ribbon cable with mounted connectors. Through this bus cable connection of power supply is achieved as well as connection to the 5024G terminal (RS485 master).

The MCE9601 module is connected to the 5024G terminal as follows:

MCE9601 CONNECTOR	CONNECTION
GND	-
B (DATA-)	5024G J4.1: RS485-B
A (DATA+)	5024G J4.2: RS485-A
GND	-
+24V	5024G J6.1: +24VDC (Vin)
GND	5024G J6.2: 0 VDC (GNDin)
I/O	-

Please notice that the internal Jumper JU 1 must be ON (inserted).

MCE2035 DIP-switch settings

The 2035 PROFIBUS-DP module is equipped with DIP-switch blocks that have the following function:

SWITCH	FUNCTION
Sw1.1-Sw1.4	Selection of AUX communication address The address is selected as the DIP-switches are binary coded, so that Sw1.1 is MSB and Sw1.4 is LSB. Note that these switches are only read during power on. The address should <u>not</u> be set so that the module has an address that matches another Profibus-DP module on the same AUX bus. The modules should be numbered from 0 and upwards without skipping any numbers. If only one module of a given type is connected to the AUX bus all switches should be OFF.

SWITCH	FUNCTION
Sw2.1	<i>Reserved for future use</i>
Sw2.2-Sw2.8	Selection of PROFIBUS-DP communication address The address is selected as the DIP-switches are binary coded, so that Sw2.2 is MSB and Sw2.8 is LSB. Note that these switches are only read during power on.

MCE2035 Jumper settings

The 2035 PROFIBUS-DP module is equipped with 4 jumpers. These jumpers have the following function:

JUMPER	FUNCTION
JU1	Baudrate on the AUX bus. OFF: Communication at 9600 bps. ON: Communication at 115200 bps. (MUST be in this position for communication with 5024G) (Normally the jumper will be mounted on delivery.)
JU2-JU4	Alternative termination of the Profibus-DP. If R17, R21 and R22 are mounted these jumpers can be used to connect the termination resistors, so this is done directly on the module and not the normal way in the Profibus-DP connectors

MCE2035 Light Emitting Diodes

The 2035 PROFIBUS-DP module is equipped with 6 light emitting diodes (LED). These LED's have the following function:

LED	FUNCTION
TXBB (Green)	Communication with AUX-master 2035 is communicating with AUX-master.
D1 (Green)	Communication with AUX-master Toggles when the 2035 module receives a valid telegram on the AUX-bus.
D2 (Green)	<i>Reserved for future use</i>
PBE (Red)	Profibus Error (when initializing the SPC3) The SPC3 Profibus-DP controller was not initialized correctly.
DES (Yellow)	Data Exchange State Exchange of data between slave and master.
RTS (Yellow)	RtS signal (SPC3) The Profibus-DP module sends to the master.

MCE2035 Profibus-DP connector

The 2035 PROFIBUS-DP module is equipped with a nine pole female sub-D connector (J1) for connection to the PROFIBUS-DP network. The connector is a standard PROFIBUS-DP connector. Termination of the PROFIBUS-DP should take place in the sub-D connector (male) of the cable. The specific terminals in the connector have the following function:

J1 Terminals	Function
J1.1	Not used
J1.2	Not used
J1.3	RS485-A (positive line) (Siemens designation: B line)
J1.4	Request to Send (RTS)
J1.5	0 VDC (Gnd)
J1.6	+5VDC (Vout)
J1.7	Not used
J1.8	RS485-B (negative line) (Siemens designation: A line)
J1.9	Not used

Note that some companies use different designations for the RS485-A and the RS485-B lines. Therefore the polarity of the lines has been listed.

Appendix D – 2070 PROFINET module

If a 2070 PROFINET module is connected it must have the following software version:

2070.AUXSLAVE.200311.1v4 (or newer)

It is possible to connect the 2070 communication module to an PROFINET network, where it will act as a slave. It will then be possible from the PROFINET master to transfer data to/from the 5024G terminal (RS485 master).

2070 Checklist during installation

During installation of the system the following should be checked/performed:

1. All hardware connections are made as described below.
2. If necessary, the PROFINET master should be configured to communicate with the 2070 PROFINET module using the supplied GSDML file.
3. Set the RS485 communication address by use of **SW1.1 – SW1.4** as described later.
4. The 2070 PROFINET module is connected to the PROFINET network using the PORT1 PROFINET connector (and possibly also PORT2) in the front of the 2070 module.
5. The 2070 PROFINET module is connected to the RS485 master using the 3 pole RS485 connector (J1).
6. Power (24VDC) is applied at the two pole power connector (J2) or through the ten pole connector (J7) connected to the MCE9601 connection module using the supplied ribbon cable.
7. The PROFINET communication is started.
8. Verify that the BF, SF, MT and ST lamps of the 2070 module end up OFF.
9. Verify that the RDY lamp ends up green.
10. Verify that the TxBB lamp (green) and D1 lamp (green) on the 2070 PROFINET module starts toggling rapidly shortly after power up.
11. Verify that expected data can be transferred across the PROFINET.

2070 Connection without MCE9601

If the 2070 PROFINET module is connected to the 5024G terminal **without** an external MCE9601 connection module, the connection is made as described in the following.

The grey ten pole ribbon connector (J7) of the 2070 module is **NOT** used.

The green two pole power connector (J2) of the 2070 module is connected as follows:

2070 J2 CONNECTOR	CONNECTION
J2.1	5024G J6.1: +24VDC (Vin)
J2.2	5024G J6.2: 0 VDC (GNDin)

The green three pole RS485 connector (J1) of the 2070 module is connected as follows:

2070 J1 CONNECTOR	FUNCTION	CONNECTION
J1.1	RS485-B (DATA-)	5024G J4.1: RS485-B
J1.2	RS485-A (DATA+)	5024G J4.2: RS485-A
J1.3	0 VDC (GNDin)	5024G J4.3: RS485-GND

2070 Connection with MCE9601

If the 2070 PROFINET module is connected to the 5024G terminal **with** an external MCE9601 connection module, the connection is made as described in the following.

The green two pole power connector (J2) of the 2070 module is **NOT** used. The green three pole RS485 connector (J1) of the 2070 module is **NOT** used. Instead the grey ten pole ribbon connector (J7) of the 2070 module is used.

The ten pole connector (J7) on the 2070 module is connected to the 10 pole connector on the MCE9601 connection module using the supplied ribbon cable with mounted connectors. Through this bus cable connection of power supply is achieved as well as connection to the 5024G terminal (RS485 master).

The MCE9601 module is connected to the 5024G terminal as follows:

MCE9601 CONNECTOR	CONNECTION
GND	-
B (DATA-)	5024G J4.1: RS485-B
A (DATA+)	5024G J4.2: RS485-A
GND	5024G J4.3: RS485-GND
+24V	5024G J6.1: +24VDC (Vin)
GND	5024G J6.2: 0 VDC (GNDin)
I/O	-

2070 DIP-switch settings

The 2070 PROFINET module is equipped with a 4 pole DIP switch block located in the front of the module. This DIP switch block is named **SW1** and has the following function:

SWITCH	FUNCTION
SW1.1 – SW1.4	Selection of RS485 communication address The address is selected as the DIP-switches are binary coded, so that SW1.1 is MSB and SW1.4 is LSB. Note that these switches are only read during power on. The address should <u>not</u> be set so that the module has an address that matches another PROFINET module.

The 2070 PROFINET module is also equipped with an 8 pole DIP switch block also located in the front of the module. This DIP switch block is named **SW2** and has the following function:

SWITCH	FUNCTION
SW2.1 – SW2.8	<i>Reserved for future use</i>

2070 Jumper settings

The 2070 PROFINET module is internally equipped with 6 jumpers. These jumpers have the following function:

JUMPER	FUNCTION
JP11	STM32 RESET The jumper allows reset of the onboard STM32 microcontroller. OFF: Normal operation (normal setting from factory) ON: Reset of the 2070 on-board microcontroller
JP12	STM32 BOOT0 The jumper is used when downloading new software to the 2070 module using the J8 serial connector. OFF: Normal power-up/operation (normal setting from factory) ON: Download operation possible
P2	STM32 configuration jumper (Reserved for future use)
P3	STM32 configuration jumper (Reserved for future use)
JP1	TPS-1 RESET Not used. Must be in OFF position.
JP2	TPS-1 BOOT1 Not used. Must be in OFF position.

2070 Light Emitting Diodes

The front of the 2070 PROFINET module is equipped with a number of status lamps (light emitting diodes). These have the following functionality:

LED	FUNCTION
PORT1 connector (Green) (RJ45)	Link (PORT1) PROFINET is connected.
PORT1 connector (Yellow) (RJ45)	Activity (PORT1) PROFINET data is received or transmitted.
PORT2 connector (Green) (RJ45)	Link (PORT2) PROFINET is connected.
PORT2 connector (Yellow) (RJ45)	Activity (PORT2) PROFINET data is received or transmitted.
TxBB (Green)	2070 communication with AUX-master PROFINET module is communicating with AUX-master.
BF (Red)	Bus Fail LED The 2070 Bus Fail LED can be lit/flashing depending on the status of the network. The function of the BF LED is given below.
SF (Red)	System Fail LED The 2070 System Fail LED can be lit/flashing depending on the status of the system. The function of the SF LED is given below.
MT (Yellow)	MainTenance required LED The 2070 MainTenance required LED can be lit/flashing depending on the status of the system. The function of the MT LED is given below.
RDY (Green)	ReaDY LED The 2070 device ReaDY LED can be lit/flashing depending on the status of the device. The function of the RDY LED is given below.
ST (Red)	<i>Reserved for future use</i>
D1 (Green)	Communication with RS485 master Toggles when the PROFINET module receives a valid telegram on the RS485 bus.

The TXBB, BF, SF, MT, RDY, ST and D1 LED's display the status of the PROFINET device, and can in conjunction with the table below be used for error finding.

LED	Color	Status	Description
BF	Red		Bus Fail:
		ON	No link status available.
		Flashing	Link status ok. No communication link to a PROFINET IO controller.
	OFF	The PROFINET IO controller has an active communication link to this PROFINET IO device.	
SF	Red		System Fail:
		ON	PROFINET diagnostic exists.
		Flashing	Reserved.
	OFF	No PROFINET diagnostic.	
MT	Yellow		Maintenance Required:
		ON	Manufacturer specific - depends on the capabilities of the device.
		Flashing	
OFF			
RDY	Green		Device Ready:
		ON	TPS-1 has started correctly.
		Flashing	TPS-1 is waiting for synchronization of the host CPU (firmware start is complete).
	OFF	TPS-1 has not started correctly.	

The 2070 PROFINET module is also equipped with a number of status lamps (LEDs) located inside the module and are only visible if the cover is removed. These have the following functionality:

LED	FUNCTION
D4 (Yellow)	RS485 RX RS485 data is received.
D9 (Green)	RS485 TX RS485 data is transmitted.
D10 (Green)	Power 3.3 VDC internal power supply is on.

2070 PROFINET connector

The front of the 2070 PROFINET module is equipped with two standard Ethernet RJ45 connectors (**PORT1** and **PORT2**) for PROFINET connection using Cat5 cables.

Appendix E – MCE9637 DeviceNet module

If a MCE9637 DeviceNet module is connected it must have the following software version:

MCE9637.AUXSLAVE.000529.2 (or newer)

It is possible to connect the MCE9637 communication module on a DeviceNet, where it will act as a slave. It will then be possible from the DeviceNet master to transfer data to/from the 5024G terminal (RS485 master).

MCE9637 DeviceNet specification

The following DeviceNet specifications apply to the MCE9637 communication module:

Protocol:	DeviceNet
Communication media:	CAN
Module type:	Group 2 slave (Polled I/O)
Baud rates [kbit/sec]:	125, 250, 500 (SW2.1-SW2.2)
DeviceNet MAC ID:	0-63 (SW2.3-SW2.8)
DeviceNet connection:	5-pin Open Connector (male)

MCE9637 Checklist during installation

During installation of the system the following should be checked/performed:

- 1) If necessary configure the DeviceNet master to communicate with the DeviceNet module (MCE9637) using the supplied EDS file.
- 2) The DeviceNet module (MCE9637) is connected to the DeviceNet, and a possible termination at the DeviceNet slave is made.
- 3) The DeviceNet module (MCE9637) baudrate is set using Sw2.1-Sw2.2 and its address is set using Sw2.3- Sw2.8. Power is applied and the DeviceNet communication is started.
- 4) Check that yellow LED (D1) of the DeviceNet module (MCE9637) is lit, and that the red LED (D2) is off. Check that the TXBB LED on the DeviceNet module flashes. Check that both the MS and the NS LED on the DeviceNet module (MCE9637) end up being lit solid green.

MCE9637 Connection

The 10 pole connector on the MCE9637 module is connected to the 10 pole connector on the MCE9601 connection module using the supplied ribbon cable with mounted connectors.

Through this bus cable connection of power supply is achieved as well as connection to the 5024G terminal (RS485 master).

The MCE9601 module is connected to the 5024G terminal as follows:

MCE9601 CONNECTOR	CONNECTION
GND	-
B (DATA-)	5024G J4.1: RS485-B
A (DATA+)	5024G J4.2: RS485-A
GND	-
+24V	5024G J6.1: +24VDC (Vin)
GND	5024G J6.2: 0 VDC (GNDin)
I/O	-

MCE9637 DIP-switch settings

The MCE9637 module is equipped with two DIP-switch blocks. DIP-switch block 1 has the following function:

SWITCH	FUNCTION
Sw1.1-Sw1.4	Selection of AUX communication address The address is selected as the DIP-switches are binary coded, so that Sw1.4 is LSB and Sw1.1 is MSB. Note that these switches are only read during power on. The address should <u>not</u> be set so that the module has an address that matches another DeviceNet module on the same AUX bus. The modules should be numbered from 0 and upwards without skipping any numbers. If only one module of a given type is connected to the AUX bus all switches should be OFF.

DIP-switch block 2 has the following function:

SWITCH	FUNCTION
Sw2.1-Sw2.2	Setting of DeviceNet DataRate (DR) The desired baudrate is set according to the table shown below. Note that these switches are only read during power-on.
Sw2.3-Sw2.8	Setting of DeviceNet Node Address (NA) The address (0-63) is set as the DIP-switches are binary coded, so that Sw2.8 is LSB and Sw2.3 is MSB. Note that these switches are only read during power-on.

The baudrate of the MCE9637 module is set according to this table:

Sw2.2	Sw2.1	Baudrate
OFF	OFF	125 kbps
ON	OFF	250 kbps
OFF	ON	500 kbps
ON	ON	Not allowed

MCE9637 Jumper settings

The MCE9637 module is equipped with 5 internal jumpers that function as follows:

JUMPER	FUNCTION
JU2	<p>Test mode</p> <p>JU2 OFF: Normal mode (Default at delivery. Shouldn't be changed). JU2 ON: Test mode.</p> <p>The jumper <u>must</u> be OFF during normal operation.</p>
JU3	<p>Baudrate on the AUX bus.</p> <p>OFF: Communication at 115200 bps. ON: Communication at 9600 bps. (Normally the jumper will NOT be mounted on delivery.)</p>
JU4	<i>Reserved for future use</i>
JU5	<i>Reserved for future use</i>
JU6	<p>Test mode</p> <p>JU6 OFF: Normal mode (Default at delivery. Shouldn't be changed). JU6 ON: Test mode.</p> <p>The jumper <u>must</u> be OFF during normal operation.</p>

MCE9637 Light Emitting Diodes

The MCE9637 module is equipped with 6 LED's that function as follows:

LED	FUNCTION
TxBB (Green LED)	<p>Communication with AUX-master</p> <p>The MCE9637 is communicating with AUX-master.</p>
D1 (Yellow LED)	<p>DeviceNet Voltage Detected</p> <p>The MCE9637 module has detected DeviceNet voltage on the DeviceNet connector.</p>
D2 (Red LED)	<p>Communication with AUX-master</p> <p>Toggles when the MCE9637 module receives a valid telegram on the AUX-bus.</p>
TxCAN (Green LED)	<p>CAN bus TxD (Transmit Data)</p> <p>The MCE9637 module transmits data across the CAN bus.</p>
MS (Green/Red LED)	<p>Module Status LED</p> <p>The MCE9637 Module Status LED, that can be lit/flashing in different colors depending on the status of the module. The function of the MS LED is given in the table below.</p>
NS (Green/Red LED)	<p>Network Status LED</p> <p>The MCE9637 Network Status LED, that can be lit/flashing in different colors depending on the status of the network. The function of the NS LED is given in the table below.</p>

Please note that the LED's will flash shortly during power-up during the selftest of the module. The MS and NS LED's will shortly flash Green/Red. The MS and NS LED's can in conjunction with the table below be used for error finding.

Light emitting diode	Color	Status	Description
MS	Green	ON	Normal Operation. Communication performed normally.
		Flashing	Standby State. The unit needs supervision.
	Red	ON	Unrecoverable fault. A timer error, memory error or other system error. The unit may need replacing.
		Flashing	Recoverable fault. Configuration error, DIP-switch not set correct or similar error. Correct error and restart unit.
---	OFF	No power. The power is disconnected or the unit is being restarted.	
NS	Green	ON	On-Line, Connection OK. The unit is On-Line and a connection with the master has been established.
		Flashing	On-Line, No Connection. The unit is On-Line but no connection to the master has been established.
	Red	ON	Critical Communication Error. The unit has detected an error that makes it impossible to communicate on the network (duplicate MAC Id or Bus-Off error).
		Flashing	Communication Time-Out. One or more I/O connections are in the Time-Out state.
	---	OFF	No power/Off-line. The device may not be powered.

MCE9637 DeviceNet connector

The MCE9637 module is equipped with a 5 pole connector for connection to DeviceNet. The connection is according to the DeviceNet specification and is made as follows:

<u>J2 Connector</u>	<u>Function</u>	<u>Color</u>
J2.1	V-	(Black) (0VDC input)
J2.2	CAN_L	(Blue)
J2.3	SHIELD	(Grey)
J2.4	CAN_H	(White)
J2.5	V+	(Red) (24VDC input)

Appendix F – 2050 Ethernet-IP module

If a 2050 Ethernet module (with Ethernet-IP protocol) is connected it must have the following software version:

2050.AUXSLAVE.140422.2v3 (or newer)

It is possible to connect the 2050 communication module to an Ethernet-IP network, where it will act as a slave. It will then be possible from the Ethernet-IP master to transfer data to/from the 5024G terminal (RS485 master).

2050 Ethernet-IP specification

The 2050 Ethernet module confirms with the following Ethernet-IP specifications:

Protocol:	Ethernet-IP
Media:	Ethernet
Module type:	Slave(/Target)
Communication settings	10MB/s, Half duplex
IP-Address:	Fixed (default: 192.168.1.199)
Ethernet connection:	RJ45/Cat5
System setup:	RS232 terminal interface

2050 Checklist during installation

During installation of the system the following should be checked/performed:

1. All hardware connections are made as described below.
2. If necessary connect the 2050 Ethernet module to a PC with a RS232 connection and setup IP Address etc. as described below.
3. If necessary the Ethernet-IP master should be configured to communicate with the 2050 Ethernet module using the supplied EDS file.
4. The 2050 Ethernet module is connected to the Ethernet-IP network using the RJ45 Ethernet connector in the front panel.
5. Power (24VDC) is applied through the two pole connector (J2) or through the ten pole connector (J7) connected to the MCE9601 connection module using the supplied ribbon cable.
6. The Ethernet-IP communication is started.
7. Verify that the **MS** lamp and the **NS** lamp both end up green.
8. Verify that none of the **D1** or **D2** lamps are lit.

2050 Connection without MCE9601

If the 2050 Ethernet module is connected to the 5024G terminal **without** an external MCE9601 connection module, the connection is made as described in the following.

The grey ten pole ribbon connector (J7) of the 2050 module is **NOT** used.

The green two pole power connector (J2) of the 2050 module is connected as follows:

2050 J2 CONNECTOR	CONNECTION
J2.1	5024G J6.1: +24VDC (Vin)
J2.2	5024G J6.2: 0 VDC (GNDin)

The green three pole RS485 connector (J1) of the 2050 module is connected as follows:

2050 J1 CONNECTOR	FUNCTION	CONNECTION
J1.1	RS485-B (DATA-)	5024G J4.1: RS485-B
J1.2	RS485-A (DATA+)	5024G J4.2: RS485-A
J1.3	0 VDC (GNDin)	5024G J4.3: RS485-GND

2050 Connection with MCE9601

If the 2050 Ethernet module is connected to the 5024G terminal **with** an external MCE9601 connection module, the connection is made as described in the following.

The green two pole power connector (J2) of the 2050 module is **NOT** used. The green three pole RS485 connector (J1) of the 2050 module is **NOT** used. Instead the grey ten pole ribbon connector (J7) of the 2050 module is used.

The ten pole connector (J7) on the 2050 module is connected to the 10 pole connector on the MCE9601 connection module using the supplied ribbon cable with mounted connectors. Through this bus cable connection of power supply is achieved as well as connection to the 5024G terminal (RS485 master).

The MCE9601 module is connected to the 5024G terminal as follows:

MCE9601 CONNECTOR	CONNECTION
GND	-
B (DATA-)	5024G J4.1: RS485-B
A (DATA+)	5024G J4.2: RS485-A
GND	5024G J4.3: RS485-GND
+24V	5024G J6.1: +24VDC (Vin)
GND	5024G J6.2: 0 VDC (GNDin)
I/O	-

2050 DIP-switch settings

The 2050 Ethernet module is equipped with an external DIP switch block (S1) as well as an internal DIP switch block (S2). These DIP switch blocks are NOT used and all switches should be left OFF.

SWITCH	FUNCTION
Sw1.1-Sw1.8	Reserved for future use

SWITCH	FUNCTION
Sw2.1-Sw2.8	Reserved for future use

2050 Light Emitting Diodes

The 2050 Ethernet module is equipped with a number of status lamps (LEDs) located in the front panel. These have the following functionality:

LED	FUNCTION
TxBB (Green)	2050 communication with AUX-master 2050 is communicating with AUX-master.
Ethernet connector (RJ45) Yellow	Link Ethernet is connected.
Ethernet connector (RJ45) Green	Activity Ethernet data is received or transmitted.
MS (Green/Red)	Module Status LED The 2050 Module Status LED, that can be lit/flashing in different colors depending on the status of the module. The function of the MS LED is given in the table below.
NS (Green/Red)	Network Status LED The 2050 Network Status LED, that can be lit/flashing in different colors depending on the status of the network. The function of the NS LED is given in the table below.
D1 (Red)	<i>Reserved for future use</i>
D2 (Red)	<i>Reserved for future use</i>

The MS and NS LED's can in conjunction with the table below be used for error finding.

Light emitting diode	Color	Status	Description
MS	Green	ON	Normal Operation. Communication performed normally.
		Flashing	Standby State. The module needs supervision.
	Red	ON	Unrecoverable fault. A timer error, memory error or other system error. The module may need replacing.
		Flashing	Recoverable fault. Configuration error, DIP-switch not set correct, IP-Address error or similar error. Correct error and restart module.
	---	OFF	No power. The power is disconnected or the module is being restarted.
NS	Green	ON	On-Line, Connection OK. The module is On-Line and a connection with the master has been established.
		Flashing	On-Line, No Connection. The module is On-Line but no connection to the master has been established.
	Red	ON	Critical Communication Error. The module has detected an error that makes it impossible to communicate on the network
		Flashing	Communication Time-Out. One or more I/O connections are in the Time-Out state.
	---	OFF	No power/Off-line. The device may not be powered.

The 2050 Ethernet module is also equipped with a number of status lamps (LEDs) located inside the module and are only visible if the cover is removed. These have the following functionality:

LED	FUNCTION
D4 (Yellow)	RS485 RX RS485 data is received.
D9 (Green)	RS485 TX RS485 data is transmitted.
D14 (Yellow)	RS232 RX RS232 data is received.
D5 (Green)	RS232 TX RS232 data is transmitted.
D10 (Red)	Power 3.3 VDC internal power supply is on.

2050 RS232 connector (J4)

The small 4 pole connector (J4) at the bottom of the 2050 Ethernet module contains an RS232 communication channel. This RS232 channel is used for setup/configuration of the 2050 Ethernet module from a PC as described below. Connection to this connector is made using a special serial cable supplied by Eilersen Electric A/S.

The 4 pole connector (J4) on the 2050 module has the following connections:

J4 CONNECTOR	FUNCTION
J4.1	RS232-GND (connected to PC-GND)
J4.2	RS232-RXD (connected to PC-TXD)
J4.3	RS232-TXD (connected to PC-RXD)
J4.4	RS232-GND (connected to PC-GND)

2050 Ethernet connector (J8)

The front panel of the 2050 Ethernet module is equipped with a standard Ethernet RJ45 connector for Cat5 cables.

Appendix G – 2050 Setup and Terminal Interface

The MAC address of the 2050 Ethernet module is pre-set to a unique value within the Eilersen Electric A/S range. The default settings for IP address etc. are:

DHCP:	Disabled
IP Address:	192.168.1.199
Subnet mask:	255.255.255.0
Gateway:	192.168.1.254

These defaults can be altered by connecting the RS232 connector (J4) to a COM port on a PC and starting a terminal emulation program (like HyperTerminal or RealTerm) with these settings:

Baudrate:	9600
Databits:	7
Parity:	Even
Stopbits:	1
Flow control:	None

When the 2050 is powered the following will be displayed

```
Eilersen Electric A/S  
2050 module.  
Software version: EthernetIP.111025.1.1
```

```
-----  
--- MAIN MENU  
(1) show Info  
(2) change Settings  
(3) reset and switch to Download mode  
-----
```

2050 IP address setting

To get the main menu press "Enter" one or more times until the main menu is displayed:

```
-----  
--- MAIN MENU  
(1) show Info  
(2) change Settings  
(3) reset and switch to Download mode  
-----
```

Then press "2" to the *Change Settings Menu* displayed:

```
-----  
--- CHANGE SETTINGS MENU  
(1) change Mac address  
(2) select enable of Dhcp  
(3) change Ip address  
(4) change Subnet mask  
(5) change Gateway address  
(6) Return to Main Menu  
-----
```

Then press "3" to change to entry of a new IP address. The display will be like this:

```
*****  
*** ENTER NEW IP ADDRESS:  
Enter IP address in decimal (ddd.ddd.ddd.ddd) and press 'Enter':
```

Now enter a new IP address (e.g. 192.168.1.109) and press enter. Change the Subnet Mask and the Gateway Address the same way if necessary. **DO NOT** change the factory set MAC address. Do not enable DHCP if a DHCP server is not present.

To check all settings re-power the device and in the *Main Menu* press “1” to select the *System Info* display looking like this

```
*****  
*** SYSTEM INFO:  
MAC Address: 00 50 c2 c5 30 10  
Use DHCP: No (use statically assigned addresses - see below)  
IP Address: 192.168.1.109  
Subnet Mask: 255.255.255.0  
Gateway IP: 192.168.1.254
```

Check that all settings are as expected. The device is now ready to connect to the Ethernet-IP network.

Appendix H – 2050 Ethernet-IP connection to Allen Bradley

To connect the 2050 Ethernet module with Ethernet-IP protocol to an Allen Bradley (Rockwell Automation) PLC using the Logix 5000 software the following must be observed:

1. Use the “ETHERNET MODULE Generic Ethernet Module
2. Do **NOT** use unicast, always use multicast.
3. Set connection format to “SINT”
4. Set “Input” “Assembly instance to 103, “Size” 14 (8-bit)
5. Set “Output” “Assembly instance to 102, “Size” 14 (8-bit)
6. Set “Configuration” “Assembly instance to 101, “Size” 1 (8-bit)

Ethernet-IP communication – Master input

Ethernet-IP communication from the 2050 Ethernet module uses a single Assembly consisting of 14 bytes data as specified in the EDS file:

Assembly:	Assem3	Input
Assembly instance:	103	(0x67)
Connection:	Connection1	Exclusive Owner
Transfer class	Class 1	

The data bytes transferred to the master (PLC) using this assembly, are structured and used as previously described.

Ethernet-IP communication – Master output

Ethernet-IP communication to the 2050 Ethernet module uses a single Assembly consisting of 14 bytes data as specified in the EDS file:

Assembly:	Assem2	Output
Assembly instance:	102	(0x66)
Connection:	Connection1	Exclusive Owner
Transfer class	Class 1	

The data bytes transferred from the master (PLC) using this assembly, are structured and used as previously described.

Appendix I – 2070 Tips for PROFINET configuration

MAC addresses

The MAC addresses of the 2070 PROFINET module are noted on a label on the side of the 2070 module. The MAC addresses of the 2070 module are pre-set to unique values within the Eilersen Electric A/S range.

GSDML file

The supplied GSDML can be used to configure the PROFINET master to communicate with the 2070 PROFINET module.

Please note that on a Siemens SIMATIC STEP 7 software platform, once the GSDML file has been imported, the imported 2070 PROFINET module will normally be placed in the following location of the “Hardware catalog”:

Other field devices \ PROFINET IO \ I/O \ Eilersen Electric \ 2x70 AUXSLAVE

Factory settings

Upon delivery the 2070 PROFINET module contains the following default factory settings:

Device Name:	d2x70
IP Address:	192.168.1.199
Subnet Mask:	255.255.255.0
Default Gateway:	192.168.1.254
Vendor ID:	840 (0x348)
Device Type:	D2x70

Setting DeviceName, IP Address etc.

The default factory settings of the 2070 PROFINET module, such as device name (d2x70) and IP address (192.168.1.199) etc., must be changed according to the actual PROFINET configuration.

Please note that on a Siemens SIMATIC STEP 7 software platform (TiA Portal), this is normally done under "Online Access" where the different node parameters (MAC address, IP address, DeviceName etc.) can be viewed and changed.

Data sizes

The amount of data exchanged between the PROFINET master and the 2070 PROFINET module is specified in the GSDML file. This application with the software specified on the front page of the manual uses 14 input bytes and 14 output bytes.

NOTE: Please beware that the terms "input" and "output" may be confusing and are used differently from vendor to vendor. Throughout this manual, these terms are always from the PROFINET masters (PLC's) point of view. Therefore, the data from the 2070 module to the PLC are referred to as "input" data, while the data from the PLC to the 2070 module are referred to as "output" data.

Revision History

Date	Author	Rev.	Update
2018-11-28	HJA	4v0	<i>Initial document created and adapted. (based on StdLim-140630-3v0-OG-ExtModule-eng)</i>
2019-01-10	HJA	5v0	<i>Based on StdLim-140630-4v0-OG-ExtModule-eng, but: Adapted screens overview in Appendix A.</i>
2019-02-19	HJA	5v1	<i>Updated references to software ID.</i>
2019-04-24	jk	5v2	<i>Updated references to software ID.</i>
2019-05-20	jk	5v3	<i>Updated references to software ID.</i>
2019-09-03	HJA	5v4	<i>Added Intelligent Setup to screens overview.</i>
2020-02-18	HJA	5v6	<i>Added ETHERNET STATUS screen in overview.</i>
2020-09-08	HJA	5v7	<i>Updated references to software ID.</i>
2021-02-11	HJA	5v8	<i>Updated references to software ID.</i>
2021-05-07	HJA	6v0	<i>Updated references to software ID.</i>
2021-09-21	HJA	6v0a	<i>Corrected error in Sw2 usage indications for MCE2035 module.</i>
2021-11-12	HJA	6v0b	<i>Added MAINTENANCE screen to screens overview.</i>
2022-01-19	HJA	6v1	<i>Updated references to software ID.</i>
2022-03-29	HJA	6v2	<i>Updated references to software ID.</i>
2022-05-19	HJA	6v2a	<i>Added figure of the rear side of the 5024 terminal.</i>
2022-11-28	HJA	6v3	<i>Updated references to software ID.</i>
2023-02-23	HJA	6v4	<i>Updated references to software ID.</i>
2023-05-30	HJA	6v5	<i>Updated references to software ID.</i>
2023-08-09	HJA	6v5a	<i>Updated references to software ID for AuxSlave.</i>
2023-08-29	HJA	6v6	<i>Updated references to software ID.</i>
2024-09-02	HJA	6v7	<i>Added LINEARIZATION SETTINGS screen. Added LINEARIZATION PROCEDURE screen.</i>
2025-02-26	HJA	6v8	<i>Updated references to software ID.</i>

Contact

With further questions or improvement suggestions please contact us:

Eilersen

The Weighing Experts

Eilersen Electric A/S
Kokkedal Industripark 4
DK-2980 Kokkedal
Denmark
www.eilersen.com
info@eilersen.com
Tel: +45 49 180 100
Fax: +45 49 180 200

Eilersen
The Weighing Experts